



**LB-302G RTX,
LB-302G RTX TRU-2**

**Single and Two Speed
Batch Freezer – Floor Model**



PERFECT GELATO, ICE CREAMS, & SORBETS WITH EVERY BATCH!

The all new LB-302G RTX Batch Freezers incorporate the latest in state-of-the-art Batch Freezer technology, offering a greater range of batch sizes with precision control of product quality. Make large or small quantities of your favorite Gelato, Ice Cream, Sorbet, Sherbet, Water Ice and more, with consistent results. Our patented Hard-O-Dynamic system produces a consistent finished product, regardless of batch size, with greater stability and better storage characteristics. Carpigiani batch freezers offer the lowest power consumption in the industry while providing some of the quickest batch times.

Features Include:

- Patented Hard-O-Dynamic technology achieves consistency with any batch size
- Patented Automatic Control provides unparalleled flexibility and ease of operation
- TRU-2 model provides the greatest flexibility in the industry to create the widest range of products
- Audible alarm signals when product achieves desired consistency
- Electronic controls automatically maintain consistency until extraction begins
- Maximized extraction results in minimal flavor overlap with less frequent rinsing
- Built-in faucet with flex hose makes cleaning fast and easy
- Ready for remote diagnostics and repairs



800-648-4389 • 336-661-9893 • Fax: 336-661-9895 • P.O. Box 4069 • Winston-Salem, NC 27115

www.carpigiani-usa.com • info@carpigiani-usa.com



Carpigiani is also the world's leading provider of hands-on frozen dessert instruction.

Find out more at www.frozendessertuniversity.com

SPECIFICATIONS

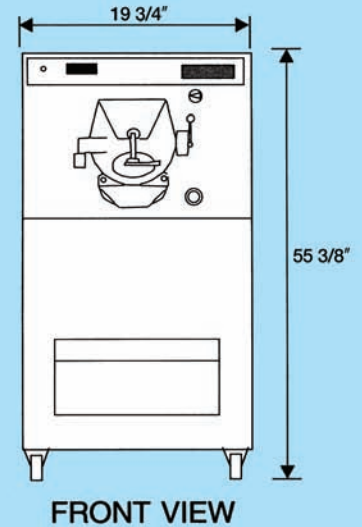
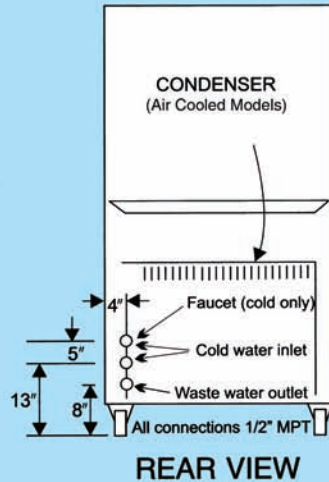
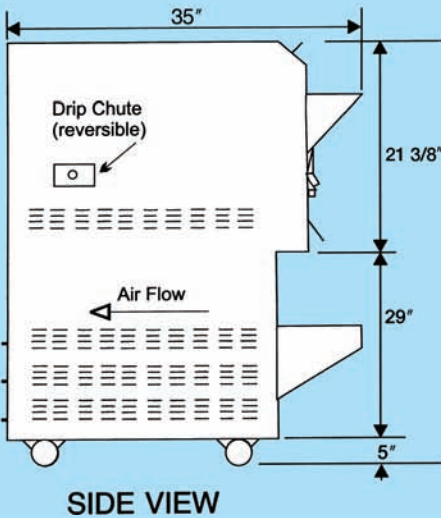
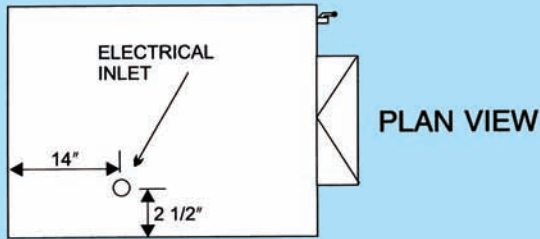

MODEL LB-302G RTX & MODEL LB-302G RTX Tru-2

Single/two speed floor model. Designed for medium to high volume requirements.

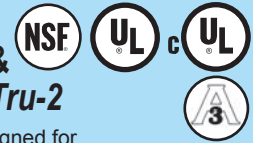

Models LB-302G RTX & LB-302G RTX Tru-2 Description	
Cylinder Capacity (w/beater)	15 Qts
Cylinder Refrig. Control System	Electronic
Cylinder Type	Helicoidal Path
Compressor Motor	2 H.P.
Water Connections	1/2" MPT
Condenser Cooling	Air or Water
Refrigerant Type	R-404A
Frame Type	Floor Model
Frame Construction	Welded Steel
Outer Panels	Stainless Steel
Faucet with Flex Hose	Standard
Beater Drive Motor	4/2 H.P.
Beater Design	Unibody w/ Replaceable Blades
5" Casters	Standard

Dimensions			
Width	Depth	Height (w/casters)	
19.3/4" (504 mm)	35" (889 mm)	55 3/8" (1412 mm)	
Weight			
Gross 660 lbs (300 kg)		Net 580 lbs (263 kg)	
Electrical Requirements			
Voltage	Phase	Cycle	Fuse/Breaker Size
208-230	3	60 Hz	35 Amps
Running Amps: 28		Number of Feeders: 1	

Carpigiani-USA manufactures a complete line of frozen dessert production equipment: Batch Freezers, Soft Serve Freezers, Yogurt Freezers, Slush Freezers, Milk Shake Machines, Granita Machines, Whipped Topping Dispensers, Frozen Custard Freezers, Specialty and Mix Processing Equipment, Display Cabinets...

Distributed by:

Something for Everyone!

All technical data, pictures, and drawings contained in this document are not binding on the manufacturer, nor can the manufacturer be held liable for any modification of the machine, in part or in whole.