

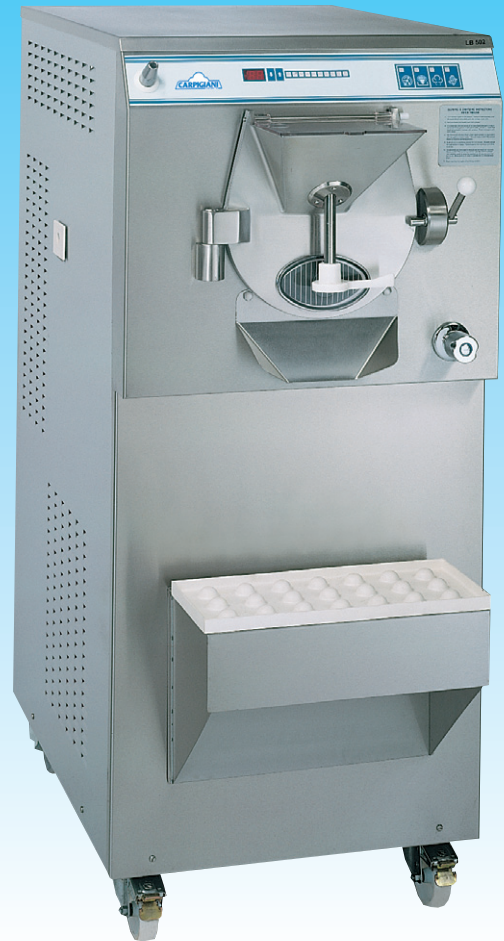

# LB-302, LB-302G, LB-302G *Tru-2*

**Single and Two Speed  
Batch Freezer – Floor Model**



Ice cream made easy! Carpigiani has enjoyed a reputation for superior quality; now it has also built a reputation for simplicity. Our fully automatic freezer with touchpad controls is simple to operate. A novice will achieve great results on the first try, yet the flexibility of our controls will satisfy even the most demanding expert. No other manufacturer offers this combination of quality and simplicity. In no time, you will begin making great premium and gourmet ice cream, gelato, sorbet, water ice and much more.

### **Features Include:**

- Automatic operation with electronic consistency control
- Unique cylinder design results in faster production and smoother finished product
- Audible alarm signals when product is ready to extract
- Cam door latch provides quick interior access
- Maximum extraction results in minimal flavor overlap
- Built-in faucet with flex hose makes cleaning fast and easy
- “G” model recommended for low overrun gourmet products, including gelato, sorbets and frozen custard
- Our new *Tru-2* Model provides the greatest flexibility in the industry to create the widest range of products



Carpigiani-USA manufactures a complete line of ice cream production equipment: Batch Freezers, Soft Serve Freezers, Yogurt Freezers, Slush Freezers, Milk Shake Machines, Whipped Topping Dispensers, Granita Machines, Frozen Custard Freezers, Mix Processing Equipment and Display Cabinets...

*Something for everyone!*

# SPECIFICATIONS

## MODEL LB-302, MODEL LB-302G & MODEL LB-302G Tru-2

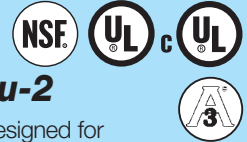

Single/Two speed Floor model, designed for medium to high volume requirements.

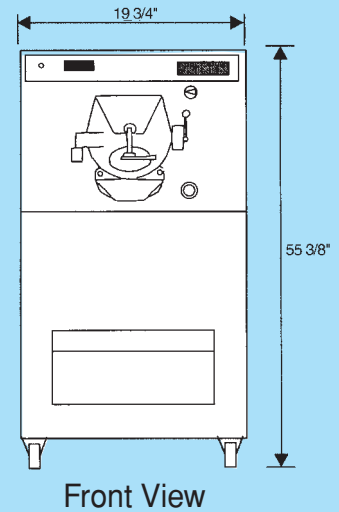
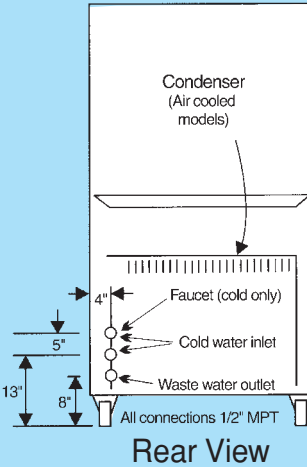
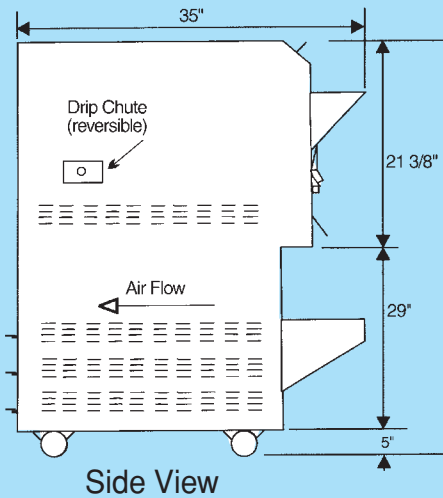
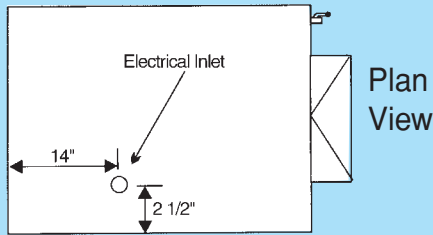

### Models LB-302, 302G & 302G Tru-2 Description:

Cylinder Capacity (w/beater) \_\_\_\_\_ 15 Qts  
 Cylinder Refrig. Control System \_\_\_\_\_ Electronic  
 Cylinder Type \_\_\_\_\_ Helicoidal Path  
 Compressor Motor \_\_\_\_\_ 3 H.P.  
 Water Connections \_\_\_\_\_ 1/2" MPT  
 Condenser Cooling \_\_\_\_\_ Air or Water  
 Refrigerant Type \_\_\_\_\_ R-404A  
 Frame Type \_\_\_\_\_ Floor Model  
 Frame Construction \_\_\_\_\_ Welded Steel  
 Outer Panels \_\_\_\_\_ Stainless Steel  
 Faucet with Flex Hose \_\_\_\_\_ Standard  
 Width \_\_\_\_\_ 19 3/4 inches (504 mm)  
 Depth \_\_\_\_\_ 35 inches\* (889 mm)  
 Height (w/casters) \_\_\_\_\_ 55 3/8 inches (1412 mm)  
 5" Casters \_\_\_\_\_ Standard

### LB-302

Beater Drive Motor \_\_\_\_\_ 2 H.P.  
 Beater Design \_\_\_\_\_ Unibody w/Delrin Blades  
 \* Water Cooled

### Model LB-302 (continued)

Net Weight \_\_\_\_\_ 520 lbs. (236 kg)  
 Gross Weight \_\_\_\_\_ 580 lbs. (263 kg)  
 Single Phase, 60 Hz \_\_\_\_\_ 208/230 V  
 Max Breaker / Fuse size \_\_\_\_\_ 30 Amps  
 Running Amps \_\_\_\_\_ 24 Amps  
 Three Phase, 60 Hz \_\_\_\_\_ 208/230 V  
 Max Breaker / Fuse size \_\_\_\_\_ 20 Amps  
 Running Amps \_\_\_\_\_ 14 Amps  
 Number of Feeders \_\_\_\_\_ 1

### Models LB-302G & 302G Tru-2

Beater Drive Motor \_\_\_\_\_ 4/2 H.P.  
 Beater Design \_\_\_\_\_ Unibody w/Replaceable Blades  
 Net Weight \_\_\_\_\_ 580 lbs. (263 kg)  
 Gross Weight \_\_\_\_\_ 660 lbs. (300 kg)  
 Three Phase, 60 Hz \_\_\_\_\_ 208/230 V  
 Max Breaker / Fuse size \_\_\_\_\_ 30 Amps  
 Running Amps \_\_\_\_\_ 23 Amps  
 Number of Feeders \_\_\_\_\_ 1



800-648-4389 • 336-661-9893 • Fax: 336-661-9895  
 P.O. Box 4069 • Winston-Salem, NC 27115  
 www.carpigiani-usa.com • info@carpigiani-usa.com

Distributed by:

All technical data, pictures, and drawings contained in this document are not binding on the manufacturer, nor can the manufacturer be held liable for any modification of the machine in part or completely.